



Universally
deployable



Switches, rails and
grooved rails



Versatile deployment
(varying track gauges)



Suitable for
tunnels

Track superstructure inspections using MR.pro[®]

Technical Datasheet

May your infrastructure have a long life – that's why we examine it so closely!

Condition-dependent, predictive maintenance is the most economical way to maintain rails and turnouts. It achieves high availability and optimum use of the wear reserve in combination with preventive elements (care and maintenance). Information is the basis for long-term material retention, and the quality of the data collected on the infrastructure's condition directly affects the quality of the maintenance. That's why inspecting infrastructure is a matter for experienced specialists who are able to handle the entire maintenance cycle from data collection, assessment and evaluation of the infrastructure's condition all the way to repair work. It's the only way to generate the information required to reliably and transparently plan, budget and schedule maintenance works.

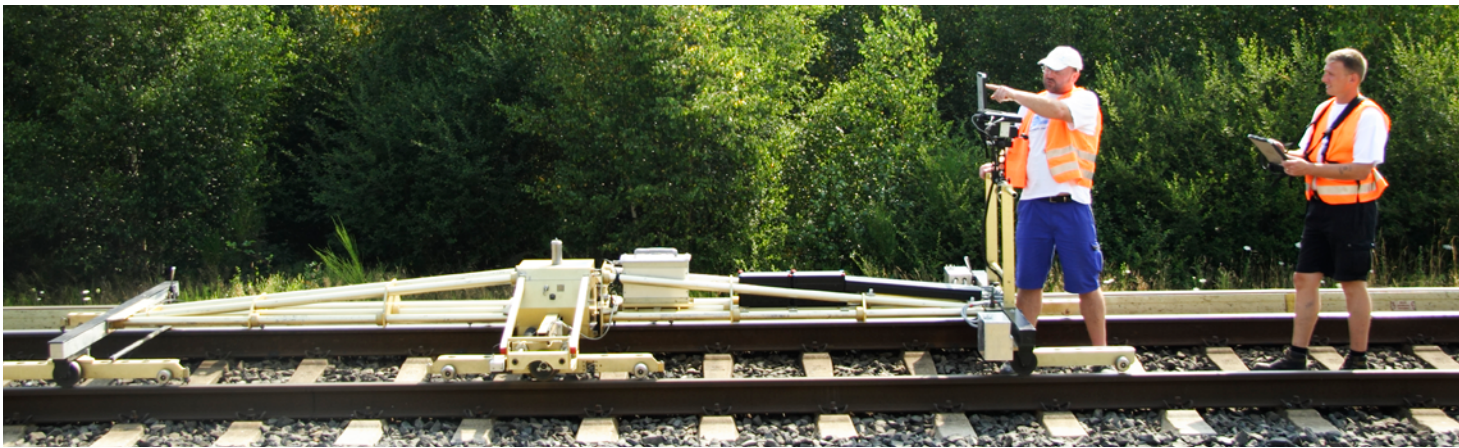

Benefits

- / High track availability
- / Significantly better quality of maintenance
- / Quick and transparent scheduling of works
- / One-stop shop
- / Optimum economic management
- / Prevents breakdowns and faults

Applications

- / Mainline track
- / Light rail
- / Connection tracks
- / Industrial railways

Inspection and Measurement
Analysis • Improved Efficiency • Long
Infrastructure Lifetime • Profitable
service life • Anticipatory Maintenance
Planning and Controlling of
Maintenance Works

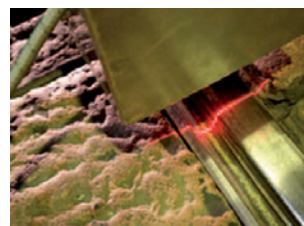

High-performance rail scanners aid in assessment and determination of corrective measures

Rail and turnout inspection Technical Data

Inspection analysis and network digitalization

Inventory and condition

Measures and priority

Geographic data and information

MR.pro® Software for Infrastructure Data Management

Analysis and evaluation

Decision-making and having work carried out

Documentation

Wheel/rail system service

Dimensioning

Track gauge inspection

Optimum interaction

Knowledge management

Asset management

Support provision for economical network maintenance

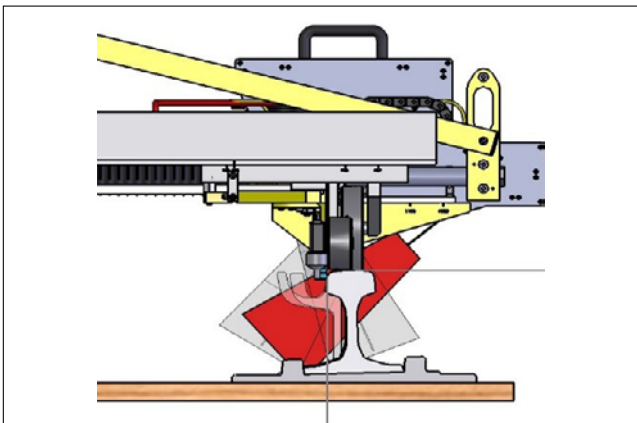

3 lasers per rail to scan in data on the rail head of grooved or flange rails

RSV Rail Laser Scan

as part of the EMA uni II track geometry wagon

| | |
|------------------------------|--|
| Fields of application | Differential measurement to determine wear and amount of material requiring removal. Continuous measurement: flange rails and grooved rails |
| Resolution per single laser | 1,280 points / profile (3 lasers = 3,740 points/rail) |
| Accuracy | +/- 0,012 % |
| Profiling incidence | 2,000 points/km of rail (2 profiles / rail, measuring interval = 0.5 meter) |
| Evaluation and documentation | MR.pro® |
| KRAB trolley (KVZ) | Geometric track inspection (also in combination with RailScan laser). The measurements are taken and the data recorded using a modified KRAB measuring trolley (KVZ) |
| Measurement data | Rail cross section is recorded |
| Tensioning axle | 2,500 mm |
| Sampling rate | 25 mm |
| Max. speed | 15 km/h |
| Track gauge | 1.435 mm +/- 1 mm (-20/+55 mm) |
| Cant | 0,1 mm (+/- 200 mm) |
| Twist | Vw +/- 1 mm (+/- 13 mm) |
| Curvature | (+/- 180 mm) Rmin 17.5 m |
| Gradient | +/- 1 mm (-15/+12 mm) |
| Alignment | 1 ‰ (m) |



Measuring the track geometry using the EMA uni

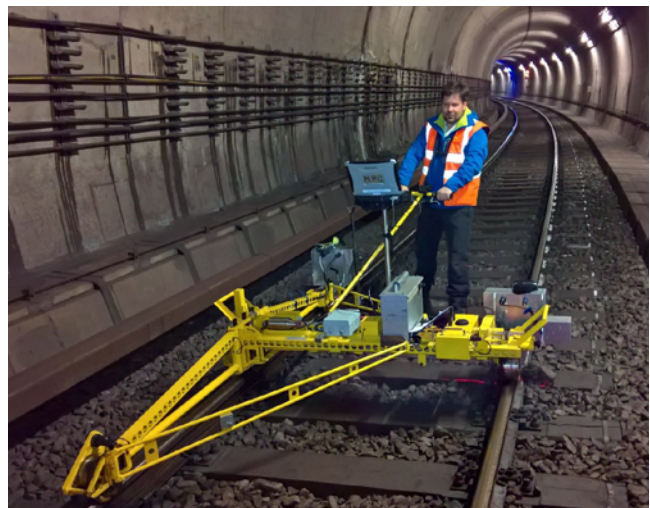

Measuring the track geometry using KRAB trolley

Digitalization of track networks

Technical data

EMA UNI (Vogel & Plötscher)

Geometric track inspection: The first digital inspection serves to divide the track network into individual test objects in order to create a complete, IT-compatible organizational framework.

| Measurements | Inner track geometry |
|--------------|---|
| Gauge | 900, 1.000, 1.100, 1.435, 1.456 mm (+35/-10 mm) |
| Cant | +/- 200 mm |
| Twist | +/- 25 mm |
| Curvature | (+/- 180 mm) Rmin 17.5 m |
| Gradient | (+/- 10 mm) |
| Alignment | 10 mm |

Documentation for quick and easy evaluation as:

Direct import into the customer's MR.pro® database

Data transfer as EXCEL workbooks and diagrams
Color printouts (Gi-doc)

Digital documentation as an Excel file consisting of:

Diagrams of the measurement results compared to the tolerances

Results of the visual inspection complete with allocated defect categories

Status report summarizing the findings

Group evaluation of all the tracks:

Results of all the test objects in one table

The Excel files can be supplemented with subsequent inspections to create a **complete history** that automatically updates itself for each of the test objects.

The documentation of switches, crossings and tracks is compatible and can be administered using MR.pro® and Microsoft Office.

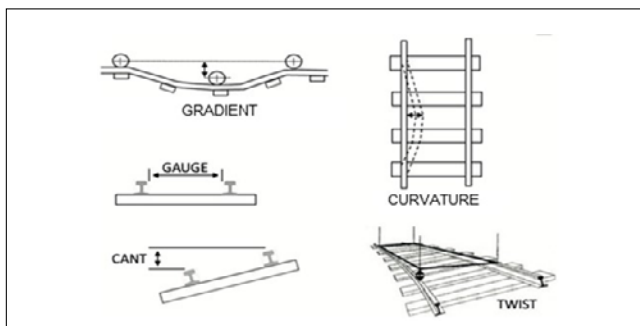

Track measurement parameters: gradient, gauge, cant, curvature and twist



Taking measurements on a switch



Visual inspection of switch

MessReg PTP

Examination (measurement) of switches and crossings using the prescribed specifications and tolerances along with their allocation to the respective minimum permissible technical requirements. If required, the geometry and model specifications can be determined in order to allocate or even draft the correct testing documentation, operational tolerances and geometry specifications. Defects are classified with respect to their relevance for safety and influence on the wear reserve in order to facilitate projectable, cost-effective and target-oriented maintenance of switches and tracks.

| | |
|--------------------------------|------------------------|
| Gauge | 10–30 measuring points |
| Groove width of the frog | 4 measuring points |
| Groove width of the check rail | 2–4 measuring points |
| Cant of the track | 2–4 measuring points |
| Distance between check rail | 2–4 measuring points |
| Rail height | 1–2 measuring points |

Documentation for quick and easy evaluation as:

Direct import into the customer's MR.pro® database

Data transfer as EXCEL workbooks and diagrams
Color printouts (Gi-doc)

Data transferred as:

Digital Excel files that are updated when the next inspection takes place to generate the history of the switch and crossing

Group evaluation: quick overview of all the switches and crossings inspected (all the master data and results are summarized in an Excel table)

Up to 5 photos of the most important defects per switch and crossing (defect photos) linked to the respective files

Classification of defects (defect category):
Classification into 4 defect categories

Visual inspection

Qualitative examination and assessment of switches and crossings in the form of a visual inspection using definable checklists and photo documentation. The comprehensive documentation facilitates a quick, easy and clearly laid out evaluation. Defects are ranked with respect to their relevance for safety and economic viability (economic lifetime). Specific measures all the way up to a schedule of service specifications can be determined.

| | |
|---|---|
| Assessment of condition | Rails, fastenings, sleepers, ballast, drainage, etc. |
| Qualifications of visual inspection specialists | Recognition of the relevance of physical parameters. Determination and evaluation of status in the highest possible quality. Assessment of the operational safety and early identification of impending damage with the aim of rectifying this damage inexpensively and thus achieving as long an economic lifetime for the asset objects as possible (material, wear reserve) |

Maintenance management and geodetic surveying

Technical data

Asset Management

The overall condition of an object is given an objective status evaluation (defect classification) using a **standardized defect diagnosis procedure**. This provides additional information and security when planning and monitoring maintenance.

| | |
|-------------------|---|
| Defect category 1 | Operational hazard requiring immediate action |
| Defect category 3 | Damage constituting a high-priority safety risk / damage must be rectified with 1 month |
| Defect category 3 | Medium-priority damage (impacting on service life), damage to be rectified in the course of the next scheduled maintenance and repair works |
| Defect category 4 | Low-priority damage/deviation from normal condition/long-term impact only/no action required |

Advantages:

- Qualifies decisions and plans
- Improves efficiency of work scheduling
- Reduces execution errors / damage
- Improves understanding of how the condition develops
- Externalizes visual inspections and status evaluations
- Meets quality management requirements
- Prepares data for central and decentralized access and for long-term analyses
- Safeguards against liability risks
- Provides confirmation of decisions made



The GIS map in the MR.pro® software and the MR.pro.cloud provide orientation

Customer Groups

Tramways, metro systems and commuter railway systems

Private railways, port railway systems and rail connections to industry

Deutsche Bahn and the national railways of other countries

Geodetic track surveys – location in space

A geodetic survey of the external geometry is required to evaluate the absolute position and location in space, which is determined using main axis points with coordinates and geometric alignment elements between neighboring points (DB Ril 883)

| |
|--|
| Carrying out acceptance measurement according to Ril 883 |
| MessReg switch inspection according to Ril 821.2005 |
| Preparing of slab track installation with GEDO CE according to Ril 883 |
| CAD system for creating and editing of as-built drawings |
| Creation of data sets for controlling tamping machines |
| Development of track geometry projects for new and existing railway installations |
| Track and switch staking as per Ril 883 |
| Geodetic fixed point field control as per Ril 883 |
| Documentation of encroachments into the clearance gauge (narrow sections) in accordance to Ril 883 |
| Drawing of site plans |
| Control and verification measurements |
| Leveling and carrying out acceptance measurement according to Ril 883 |

We have the following equipment for measuring, recording and analyzing the track's position as well as for construction and maintenance applications

Trimble GEDO CE. 1.0 consisting of tachymeter and prism trolley (gauge 1435)

Trimble Robotics Total Stations S8 and RTS633

Trimble DiNi – digital leveling devices

Trimble TSC3 Remote Control / Tablet PC Panasonic FZ-G1

Mephisto laser fixed point meter

Track and switch geometry measurement: Vogel & Plötscher MessReg and CDM, Krabbe

Various software applications e.g. field software from Trimble such as GEDO Track Survey, GEDO Office 2 (GEDO Rec, GEDO Vorsys, GEDO Tamp), Vestra Seven and BricsCAD

VW Multivan transport vehicles

Seminars and Training Courses

Vocational training and further training for technical and management staff

Specialist training courses

Operations manager

Technical expert

Points fitter

Switch mechanic

Switch inspector, etc.

Global expertise
in over 100 countries

